

**DURAGRIP AUTO-VOLTAGE  
SPOOL GUN  
MIG/MAG SERIES**

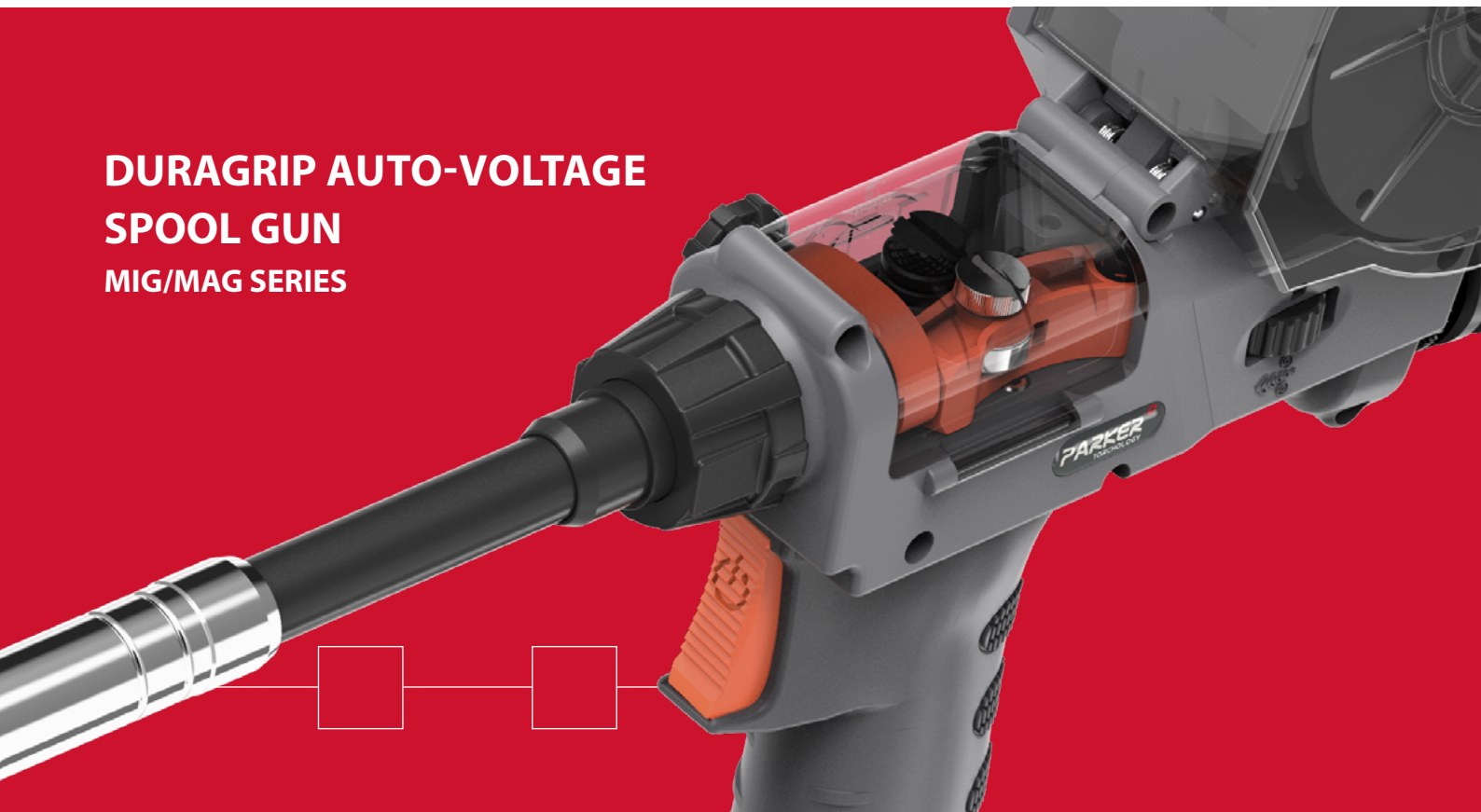

**Welding Tools for the Professional**

## A Smart Approach

Parker Torchology is shaped by people with vision, a passion for improvement and a belief in delivering the very best Welding and Cutting Torch Range in the World.

We expect a great deal from our products, so we ask a lot of ourselves and our engineers.

Our mantra: **Innovation, Technology, Performance.**



## DNA

Design and Engineering excellence are at the core of everything we do.

Every torch we build is driven by our relentless pursuit of perfection.

## Premium Features

At Parker Torchology we do things differently, we strive to solve your problems with the perfect product to suit your needs. We create smart product features encased in cutting-edge design to ensure you always have the best tools to hand.





## Production

A fusion of precision production engineering, our bespoke processing techniques and a fanatical attention to detail ensures every welding torch we produce is worthy of the Parker Torchology name.

## Testing, Testing, Testing

It takes patience to develop a new product, it's a lot more than a great idea.

Product development is an iterative process, trying something over and over, changing one small variable at a time.

We build endless prototypes and test pieces that undergo months of rigorous testing. Only once a product has passed up to 88 different test procedures, with every single part tested separately do we consider our latest designs ready for market.

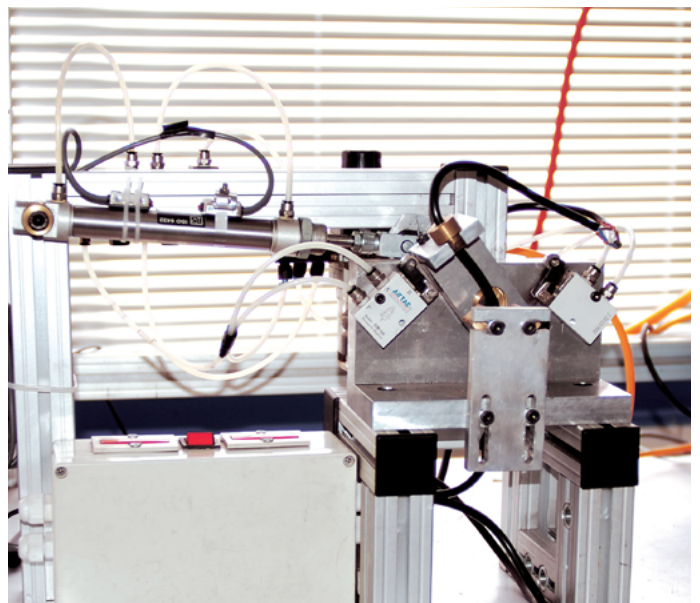

## Partners

Our customers and business partners play a vital role in our development. With the core aim to strive together, we work with end-users, distributors and academic institutions alike.

As a result we share fundamental values in order to succeed in our respective market places, supporting economic growth and collaborative opportunities with others.

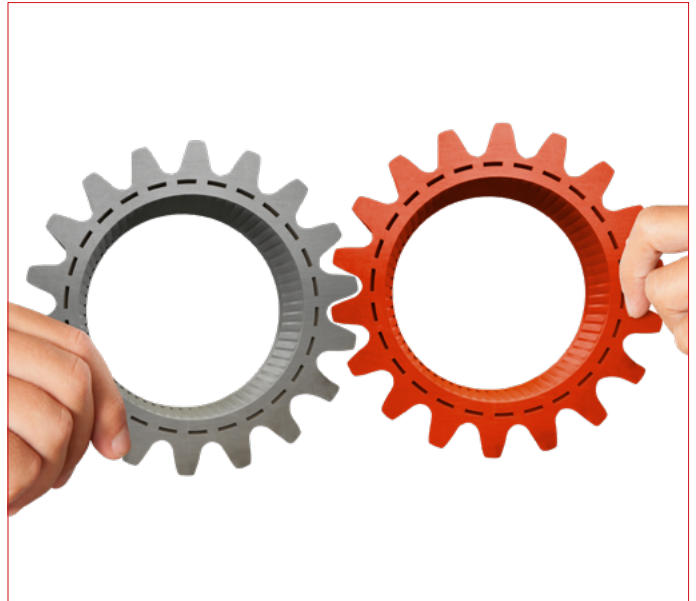

## A Bright Future

Technology doesn't stand still, which is why we are constantly innovating to bring you the best products on the market.

Our strong vision and focused innovation strategy, not to mention our passion to revolutionize the industry, ensure that Parker Torchology is a byword for excellence.

**We Talk Torches**

# Duragrip Auto-Voltage Spool Gun Mig/Mag Gun Range

## Air-Cooled Features Focus

Automatic Voltage Adjustment Guns can be mounted directly to the power source without the need to identify motor input voltage or the re-configuration of power source wiring systems.

The on-torch mounted control unit automatically configures the required motor voltage and integrates with the power source.

## A Cost Effective Solution for Long Distance and Low Deposition Welding



100% Tweco® Wear Parts Compatibility Guaranteed

### Quality Wear Parts

All wear parts are manufactured to exacting specifications ensuring reliability, longevity and superior performance

- The same wear parts are utilized as standard TWC ranges minimizing stock handling

### Ergonomics – For Comfort and Handleability

Every detail has been considered to ensure the welder has the very best handling

- New lightweight single piece coax system
- A knuckle joint enables small movements of the handle independently of the cable assembly
- Improved balance and positionability resulting in reduced welder fatigue



### Infinately Adjustable Wire Tension

- A unique lever action wire retainer and brake system holds all soft wire spools in place at the correct brake tension
- A further secondary brake system is integrated into the spool holder for independent adjustment of larger steel wires on all torches over 200 Amp

## Features Focus

### Welding Tools for the Professional



#### Precision and Visibility

- Precise and constant wire feed
- Contact pressure of the feed rollers regulated directly on the handle
- Transparent window for quick and easy reference to all moving parts
- Rapid access for wire changes

#### Torch mounted control system

##### No machine wiring required

- Single voltage motor suits all power source types
- On-torch speed adjustability
- Faster wire speeds than conventional PCB system



### The Smart Way To Buy Welding and Cutting Tools



# DSPAV TW300 Duragrip Spool Gun Mig/Mag Torch Range

Rating:230A CO<sub>2</sub>, 200A mixed gas, EN60974-7 @ 35% duty cycle. 0.6-1.2mm wires

Air-Cooled Mig Welding Torch

**PARKER**  
TORCHOLGY  
SMART TORCH SOLUTIONS

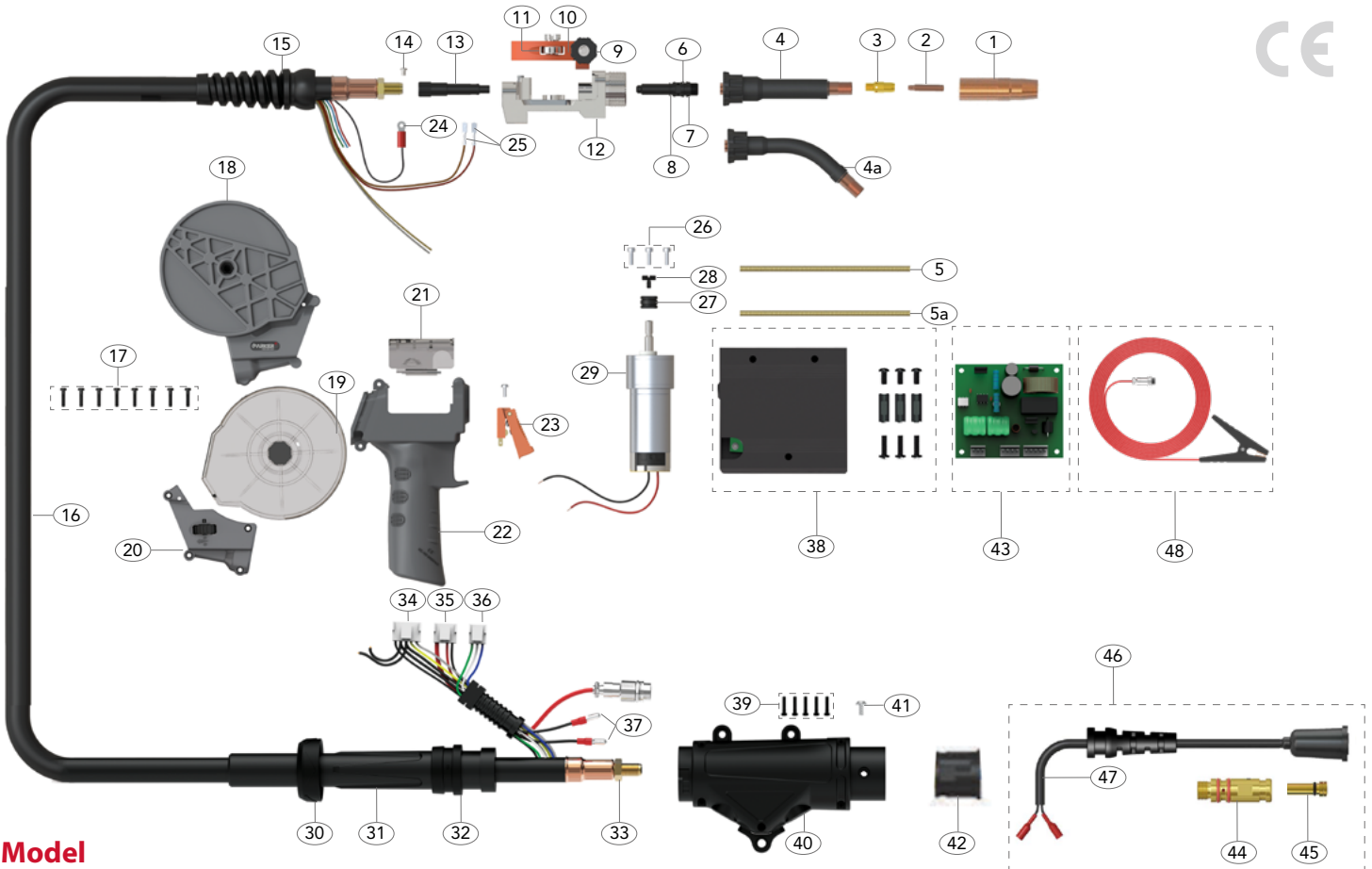

## Model

Description	Part No.
Duragrip AV Spool Gun Mig Torch Package Straight Neck,LPB End	8mt TC-DSPAVTW300-A180-24-P10-80LPB

## Spare Parts

Part No.	Description
1	P23-62 Nozzle Self Insulated
2	P14H-40 Contact Tip Ecu 1.0mm/.040"
3	P54A Gas Diffuser
4	PLS-PPTW3A Swan Neck Assembly 180°
4a	PLS-PPTW4 Swan Neck Assembly 45°
5	PPTW302A Jump Liner
5a	PGPTW302A Jump Liner
6	PGP36006 Jump Liner Nipple
7	P9X1.5 'O' Ring
8	P7X1.5 'O' Ring
9	PGP36402B Tension Knob
10	PGP36402 Pressure Arm Assembly
11	PGP36402R Pressure Roll
12	PSP36001 Motor Body
13	PSP36006 Wire Guide Tube
14	SCP2563 Screw
15	PMIG8015 Cable Support
16	DSPAV3609-80AD Coax Cable Assembly x 8m
17	PKA3X20 Handle Screw
18	PSP2515SP-B Wire Spool Holder
19	PSP2515SP-C Wire Spool Cover
20	PSP2515SP-PT-10K Wire Speed Control 10K Ω
21	PGP2514-C Push-Pull Handle Cover
22	PCSP2515-KJ Spool Gun Handle
23	PGP2516 Standard Trigger Assembly
24	SCP2597 Circular Cable Terminal
25	PB1521 Cable Terminal
26	PGPMS1 Motor Screw
27	SGP7020W-06 Drive Roll For Hard Wire φ 0.6
	SGP7020W-06U Drive Roll For Aluminium Wire φ 0.6

Part No.	Description
SGP7020W-08	Drive Roll For Hard Wire φ 0.8
SGP7020W-09	Drive Roll For Hard Wire φ 0.9
SGP7020W-10	Drive Roll For Hard Wire φ 1.0
SGP7020W-08U	Drive Roll For Aluminium Wire φ 0.8
*SGP7020W-09U	Drive Roll For Aluminium Wire φ 0.9
SGP7020W-10U	Drive Roll For Aluminium Wire φ 1.0
SGP7020W-12U	Drive Roll For Aluminium Wire φ 1.2
28	PGP7020-24-4 Drive Roller Retaining Screw
29	SGP7020-24 Motor 24V DC
30	PSC8018 Housing Lock Nut
31	PPA3541 Cable Support
32	PSP-SLH917-L Cable Support Connector
33	PXL1542 Lock Nut
34	PVH3.96-T-5A 5A Connector Female
35	PVH3.96-T-4A 4A Connector Female
36	PVH3.96-T-3A 3A Connector Female
37	PB1522 Cable Terminal Male
38	PSPCB-BOX-BK Control Box And Mounting Kit
39	PWN5452-25X12 Housing Screw
40	PSP5022L Housing Assembly c/w Control Box Brackets
41	PBL1541 Gun Plug Screw
42	PECEM1575/2 Hybrid Plug Body TWC 1-4
43	PSPCB-BOX-PCB Control Box PCB Assembly
44	PECET1575-SP-1 Tweco 1-4 Power Pin
45	PSP1826W Seal Nipple
46	TC-PSP-ECET1575K-LPB LPB Connection
47	TC-M16725 Lincoln Plug Assembly
48	PSP-EL-SILI-8M Earth Lead Wire c/w Clamp x 8m

All products conform to EN60974-7, CE and are RoHS2, REACH and WEEE compliant

Copyright © 2020. Parker Torchology. All rights reserved.

# PARKER DSPAV TW300 Duragrip Spool Gun Mig/Mag Torch Range

Rating: 230A CO<sub>2</sub> 200A mixed gas, EN60974-7 @ 35% duty cycle. 0.6-1.2mm wires  
Air-Cooled Mig Welding Torch

TORCHOLGY  
SMART TORCH SOLUTIONS

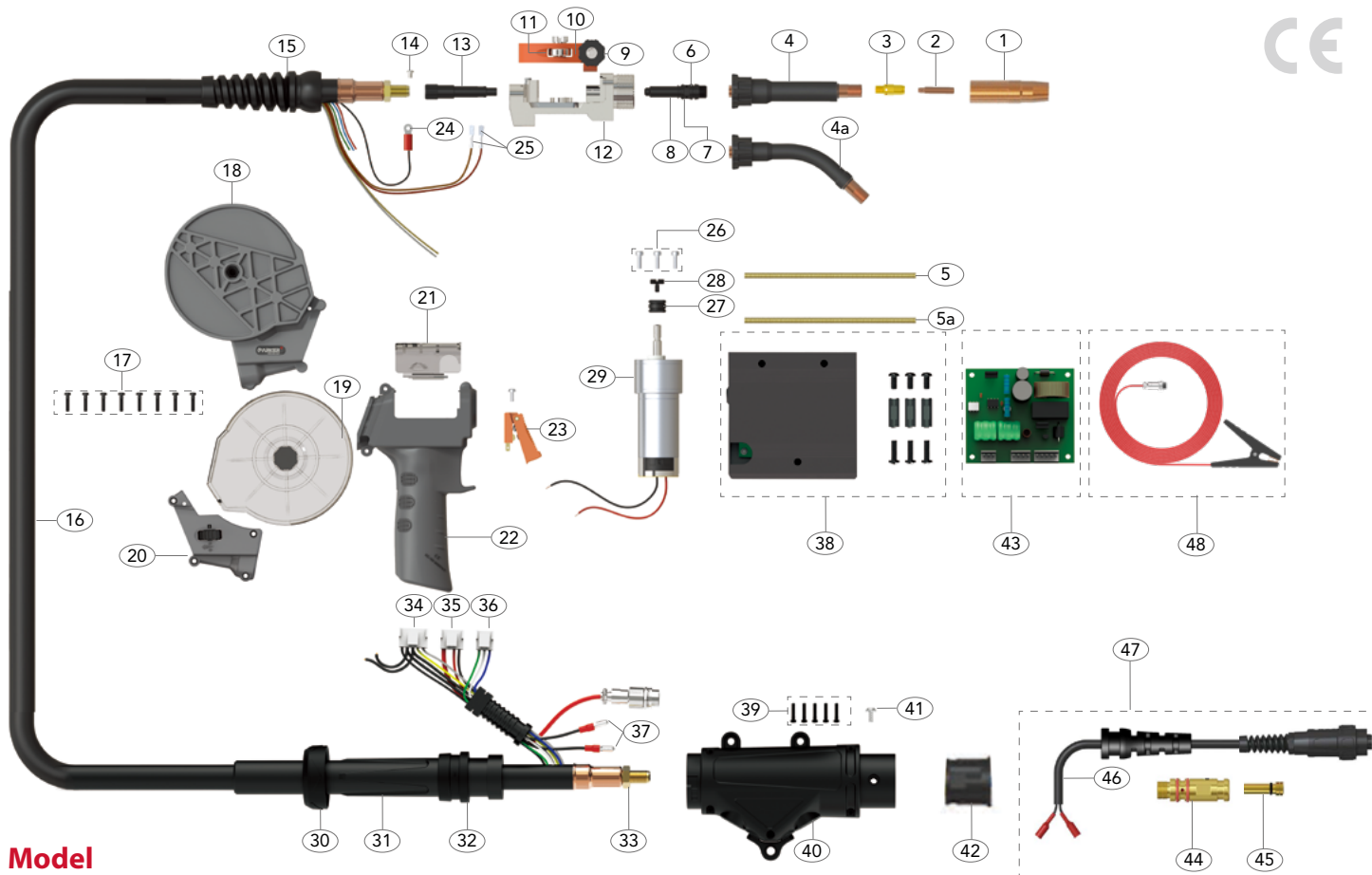

## Model

Description	Part No.
Duragrip AV Spool Gun Mig Torch Package Straight Neck, LPW End	8mt TC-DSPAVTW300-A180-24-P10-80LPW

## Spare Parts

Part No.	Description
1	P23-62 Nozzle Self Insulated
2	P14H-40 Contact Tip Ecu 1.0mm/.040"
3	P54A Gas Diffuser
4	PLS-PPTW3A Swan Neck Assembly 180°
4a	PLS-PPTW4 Swan Neck Assembly 45°
5	PPTW302A Jump Liner
5a	PGPTW302A Jump Liner
6	PGP36006 Jump Liner Nipple
7	P9X1.5 'O' Ring
8	P7X1.5 'O' Ring
9	PGP36402B Tension Knob
10	PGP36402 Pressure Arm Assembly
11	PGP36402R Pressure Roll
12	PSP36001 Motor Body
13	PSP36006 Wire Guide Tube
14	SCP2563 Screw
15	PMIG8015 Cable Support
16	DSPA3609-80AD Coax Cable Assembly x 8m
17	PKA3X20 Handle Screw
18	PSP2515SP-B Wire Spool Holder
19	PSP2515SP-C Wire Spool Cover
20	PSP2515SP-PT-10K Wire Speed Control 10K Ω
21	PGP2514-C Push-Pull Handle Cover
22	PCSP2515-KJ Spool Gun Handle
23	PGP2516 Standard Trigger Assembly
24	SCP2597 Circular Cable Terminal
25	PB1521 Cable Terminal
26	PGPMS1 Motor Screw
27	SGP7020W-06 Drive Roll For Hard Wire φ 0.6 SGP7020W-06U Drive Roll For Aluminium Wire φ 0.6

Part No.	Description
SGP7020W-08	Drive Roll For Hard Wire φ 0.8
SGP7020W-09	Drive Roll For Hard Wire φ 0.9
SGP7020W-10	Drive Roll For Hard Wire φ 1.0
SGP7020W-08U	Drive Roll For Aluminium Wire φ 0.8
*SGP7020W-09U	Drive Roll For Aluminium Wire φ 0.9
SGP7020W-10U	Drive Roll For Aluminium Wire φ 1.0
SGP7020W-12U	Drive Roll For Aluminium Wire φ 1.2
28	PGP7020-24-4 Drive Roller Retaining Screw
29	SGP7020-24 Motor 24V DC
30	PSC8018 Housing Lock Nut
31	PPA3541 Cable Support
32	PSP-SLH917-L Cable Support Connector
33	PXL1542 Lock Nut
34	PVH3.96-T-5A 5A Connector Female
35	PVH3.96-T-4A 4A Connector Female
36	PVH3.96-T-3A 3A Connector Female
37	PB1522 Cable Terminal Male
38	PSPCB-BOX-BK Control Box And Mounting Kit
39	PWN5452-25X12 Housing Screw
40	PSP5022L Housing Assembly c/w Control Box Brackets
41	PBL1541 Gun Plug Screw
42	PECEM1575/2 Hybrid Plug Body TWC 1-4
43	PSPCB-BOX-PCB Control Box PCB Assembly
44	PECET1575-SP-1 Tweco 1-4 POWER Pin
45	PSP1826W Seal Nipple
46	TC-ECEM1575/SW Switch Wire Assembly
47	TC-PSP-ECET1575K-LPW LPW Connection
48	PSP-EL-SILI-8M Earth Lead Wire c/w Clamp x 8m



# DSPAV TW300 Duragrip Spool Gun Mig/Mag Torch Range

# PARKER

**TORCHOLGY**  
SMART TORCH SOLUTIONS

Rating: 230A CO<sub>2</sub>, 200A mixed gas, EN60974-7 @ 35% duty cycle. 0.6-1.2mm wires

Air-Cooled Mig Welding Torch

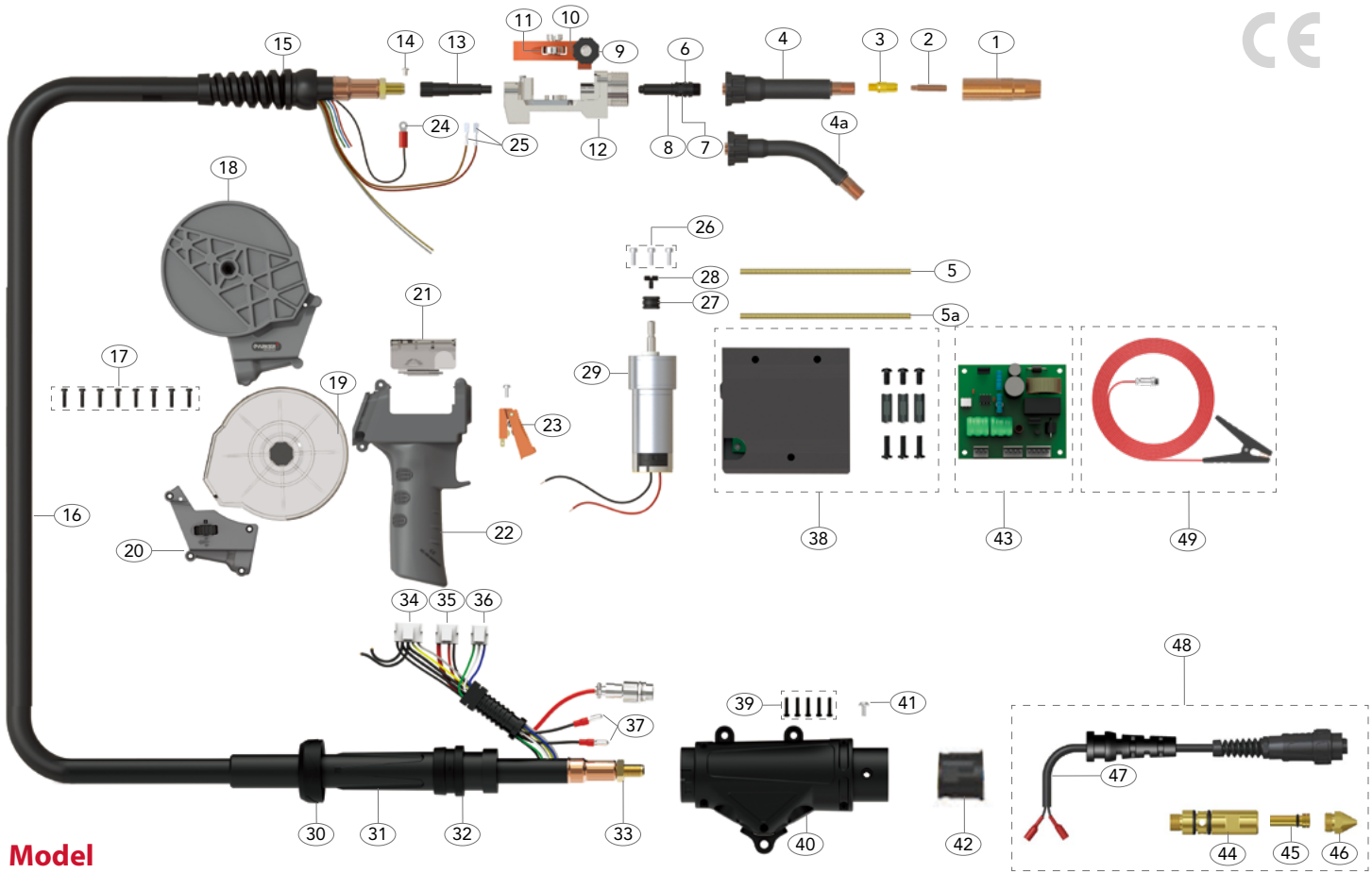

## Model

Description	Part No.
Duragrip AV Spool Gun Mig Torch Package Straight Neck, Miller End	8mt
	TC-DSPAVTW300-A180-24-P10-80M

## Spare Parts

Part No.	Description
1	P23-62 Nozzle Self Insulated
2	P14H-40 Contact Tip Ecu 1.0mm/.040"
3	P54A Gas Diffuser
4	PLS-PPTW3A Swan Neck Assembly 180°
4a	PLS-PPTW4 Swan Neck Assembly 45°
5	PPTW302A Jump Liner
5a	PGPTW302A Jump Liner
6	PGP36006 Jump Liner Nipple
7	P9X1.5 'O' Ring
8	P7X1.5 'O' Ring
9	PGP36402B Tension Knob
10	PGP36402 Pressure Arm Assembly
11	PGP36402R Pressure Roll
12	PSP36001 Motor Body
13	PSP36006 Wire Guide Tube
14	SCP2563 Screw
15	PMIG8015 Cable Support
16	DSPAV3609-80AD Coax Cable Assembly x 8m
17	PKA3X20 Handle Screw
18	PSP2515SP-B Wire Spool Holder
19	PSP2515SP-C Wire Spool Cover
20	PSP2515SP-PT-10K Wire Speed Control 10K Ω
21	PGP2514-C Push-Pull Handle Cover
22	PCSP2515-KJ Spool Gun Handle
23	PGP2516 Standard Trigger Assembly
24	SCP2597 Circular Cable Terminal
25	PB1521 Cable Terminal
26	PGPMS1 Motor Screw
27	SGP7020W-06 Drive Roll For Hard Wire φ 0.6
	SGP7020W-06U Drive Roll For Aluminium Wire φ 0.6

Part No.	Description
SGP7020W-08	Drive Roll For Hard Wire φ 0.8
SGP7020W-09	Drive Roll For Hard Wire φ 0.9
SGP7020W-10	Drive Roll For Hard Wire φ 1.0
SGP7020W-08U	Drive Roll For Aluminium Wire φ 0.8
*SGP7020W-09U	Drive Roll For Aluminium Wire φ 0.9
SGP7020W-10U	Drive Roll For Aluminium Wire φ 1.0
SGP7020W-12U	Drive Roll For Aluminium Wire φ 1.2
28	PGP7020-24-4 Drive Roller Retaining Screw
29	SGP7020-24 Motor 24V DC
30	PSC8018 Housing Lock Nut
31	PPA3541 Cable Support
32	PSP-SLH917-L Cable Support Connector
33	PXL1542 Lock Nut
34	PVH3.96-T-5A 5A Connector Female
35	PVH3.96-T-4A 4A Connector Female
36	PVH3.96-T-3A 3A Connector Female
37	PB1522 Cable Terminal Male
38	PSPCB-BOX-BK Control Box And Mounting Kit
39	PWN5452-25X12 Housing Screw
40	PSP5022L Housing Assembly c/w Control Box Brackets
41	PBL1541 Gun Plug Screw
42	PECEM1575/2 Hybrid Plug Body TWC 1-4
43	PSPCB-BOX-PCB Control Box PCB Assembly
44	TC-USP-ECEM1575/1 Miller Power Pin
45	PSP1826W Seal Nipple
46	ML1570 Wire Guide 0.35"-1/16"
47	TC-ECEM1575/SW Miller Plug Assembly
48	TC-PSP-ECEM1575K Miller Connection
49	PSP-EL-SILI-8M Earth Lead Wire c/w Clamp x 8m

All products conform to EN60974-7, CE and are RoHS2, REACH and WEEE compliant

Copyright © 2020. Parker Torchology. All rights reserved.

# PARKER TORCHOLGY SMART TORCH SOLUTIONS

## DSPAV TW300 Duragrip Spool Gun Mig/Mag Torch Range

Rating: 230A CO<sub>2</sub>, 200A mixed gas, EN60974-7 @ 35% duty cycle. 0.6-1.2mm wires  
Air-Cooled Mig Welding Torch

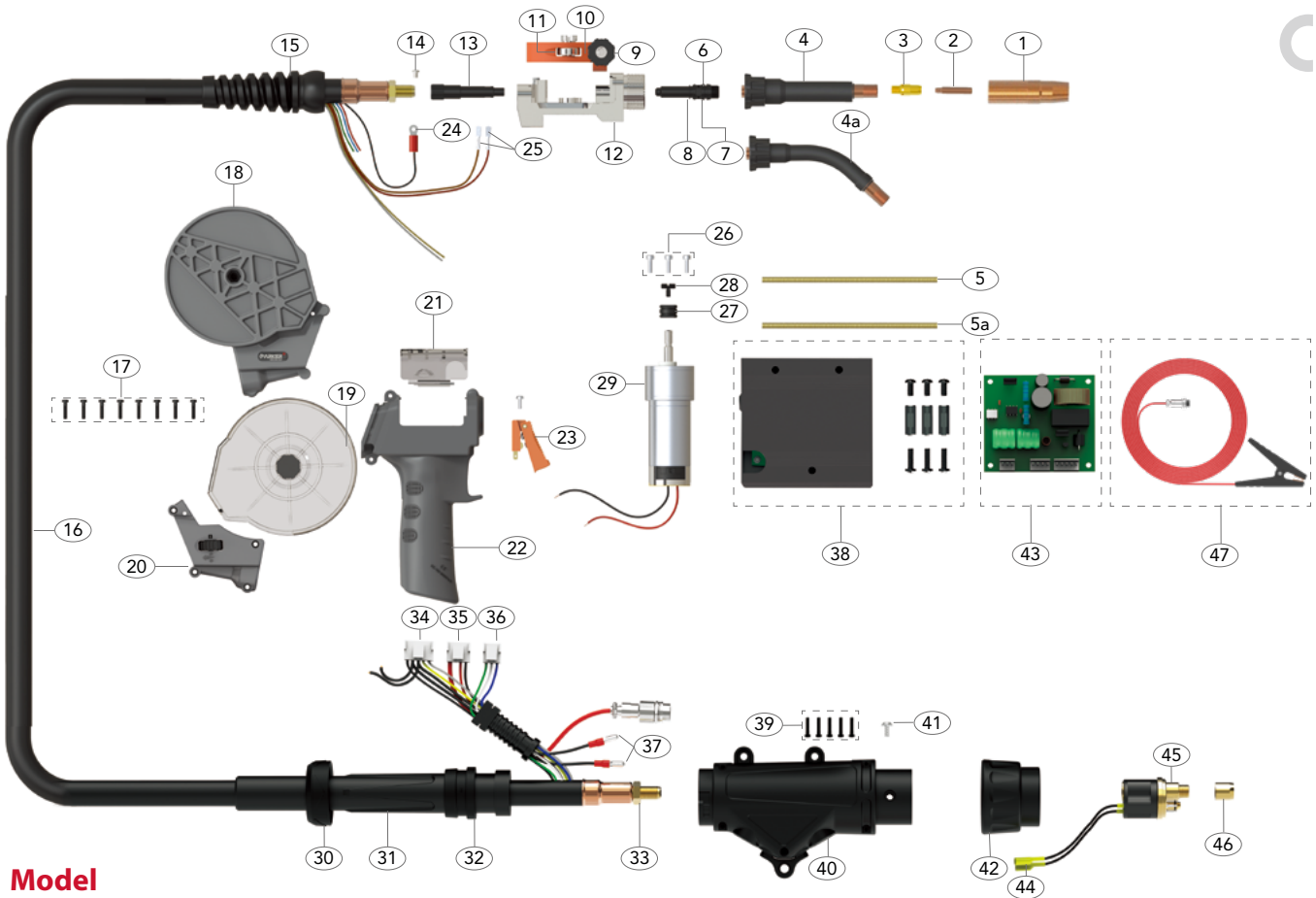

### Model

Description	Part No.
Duragrip AV Spool Gun Mig Torch Package Straight Neck, Euro End	8mt TC-DSPAVTW300-A180-24-P10-80ER

### Spare Parts

Part No.	Description
1	P23-62 Nozzle Self Insulated
2	P14H-40 Contact Tip Ecu 1.0mm/.040"
3	P54A Gas Diffuser
4	PLS-PPTW3A Swan Neck Assembly 180°
4a	PLS-PPTW4 Swan Neck Assembly 45°
5	PPTW302A Jump Liner
5a	PGPTW302A Jump Liner
6	PGP36006 Jump Liner Nipple
7	P9X1.5 'O' Ring
8	P7X1.5 'O' Ring
9	PGP36402B Tension Knob
10	PGP36402 Pressure Arm Assembly
11	PGP36402R Pressure Roll
12	PSP36001 Motor Body
13	PSP36006 Wire Guide Tube
14	SCP2563 Screw
15	PMIG8015 Cable Support
16	DSPAV3609-80AD Coax Cable Assembly x 8m
17	PKA3X20 Handle Screw
18	PSP2515SP-B Wire Spool Holder
19	PSP2515SP-C Wire Spool Cover
20	PSP2515SP-PT-10K Wire Speed Control 10K Ω
21	PGP2514-C Push-Pull Handle Cover
22	PCSP2515-KJ Spool Gun Handle
23	PGP2516 Standard Trigger Assembly
24	SCP2597 Circular Cable Terminal
25	PB1521 Cable Terminal
26	PGPMS1 Motor Screw
27	SGP7020W-06 Drive Roll For Hard Wire φ 0.6
	SGP7020W-06U Drive Roll For Aluminium Wire φ 0.6

Part No.	Description
SGP7020W-08	Drive Roll For Hard Wire φ 0.8
SGP7020W-09	Drive Roll For Hard Wire φ 0.9
SGP7020W-10	Drive Roll For Hard Wire φ 1.0
SGP7020W-08U	Drive Roll For Aluminium Wire φ 0.8
*SGP7020W-09U	Drive Roll For Aluminium Wire φ 0.9
SGP7020W-10U	Drive Roll For Aluminium Wire φ 1.0
SGP7020W-12U	Drive Roll For Aluminium Wire φ 1.2
28	PGP7020-24-4 Drive Roller Retaining Screw
29	SGP7020-24 Motor 24V DC
30	PSC8018 Housing Lock Nut
31	PPA3541 Cable Support
32	PSP-SLH917-L Cable Support Connector
33	PXL1542 Lock Nut
34	PVH3.96-T-5A 5A Connector Female
35	PVH3.96-T-4A 4A Connector Female
36	PVH3.96-T-3A 3A Connector Female
37	PB1522 Cable Terminal Male
38	PSPCB-BOX-BK Control Box And Mounting Kit
39	PWN5452-25X12 Housing Screw
40	PSP5022L Housing Assembly c/w Control Box Brackets
41	PBL1541 Gun Plug Screw
42	PB1519/S Euro Housing Nut Assembly
43	PSPCB-BOX-PCB Control Box PCB Assembly
44	PB1523 Gun Plug Terminal Female
45	PC174EX-1 Hybrid Gun Plug Body c/w Spring Pins
46	PSP1826 Seal Nut
47	PSP-EL-SILI-8M Earth Lead Wire c/w Clamp x 8m





**JINAN UNIARC WELDING TECHNOLOGY CO., LTD**

13A Zhangjin Comprehensive Bonded Zone  
33688, Jing Shi Dong Road  
Jinan Area of China (Shandong) Pilot Free Trade Zone  
Jinan 250102, P.R. China

**Tel:** +86 531 88239823

**Website:** [www.parkertorchology.com.cn](http://www.parkertorchology.com.cn)

**Email:** [info@parkertorchology.com](mailto:info@parkertorchology.com)

MPP018 / V.2023.06